

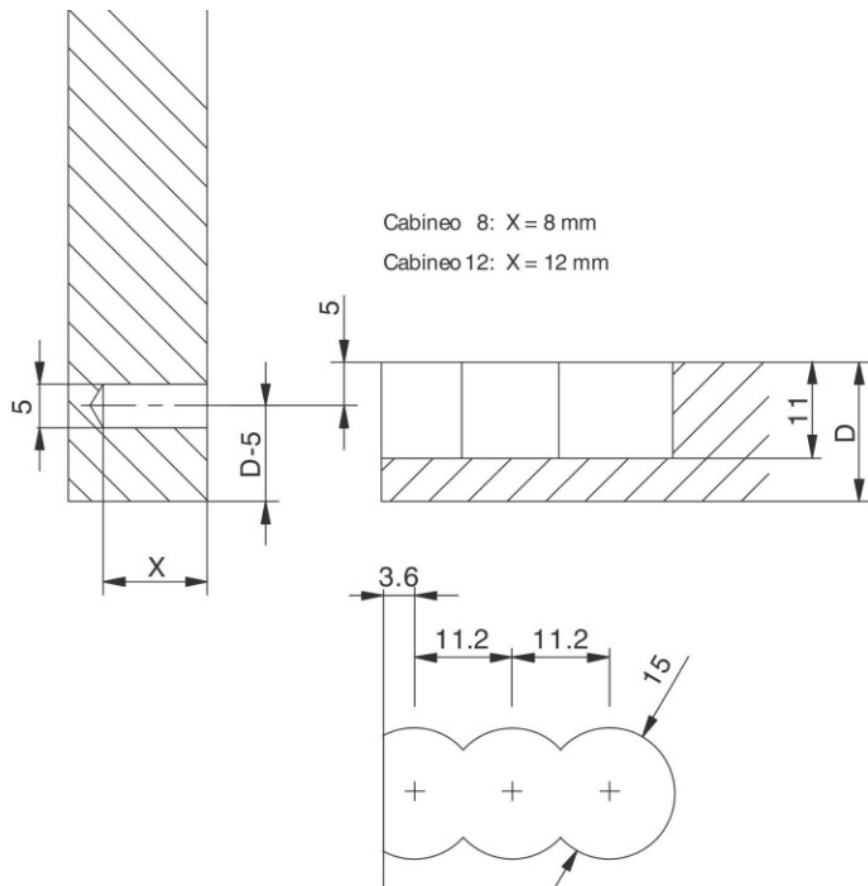

Spojovacia lamela Cabineo 12 mm (33,8x16,5x10,8 mm)

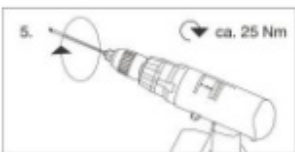

Montáž:

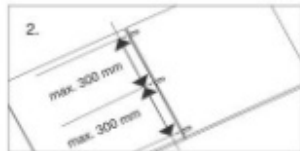

Nejsou potřeba žádné kolíky!

žádné obrábění hran / méně vrtání / méně výměn nástrojů / žádná montáž kolíků



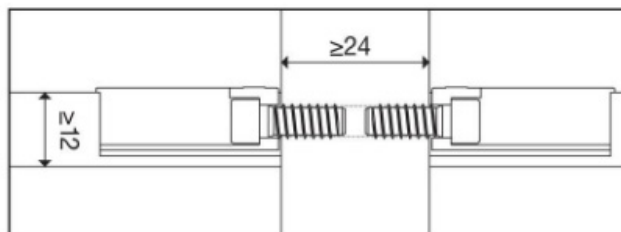
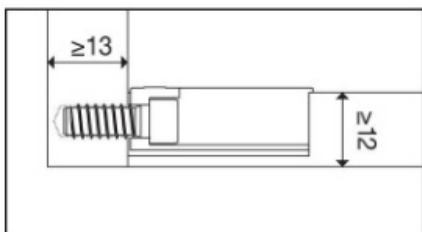

Varianty obrábění

Všechny údaje v mm

Varianta 1:
Vrták ø 15 mm

Varianta 2:
Fréza ø 10 mm nebo menší

Varianta 3:
Fréza ø 12 mm

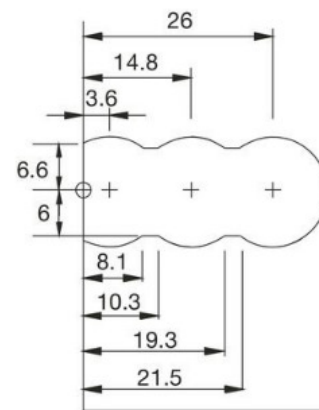
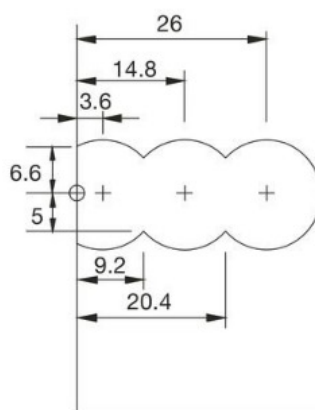
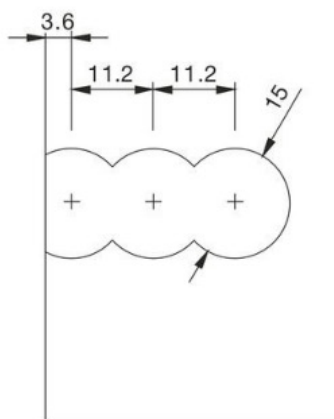
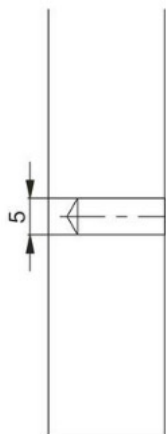

Použití:

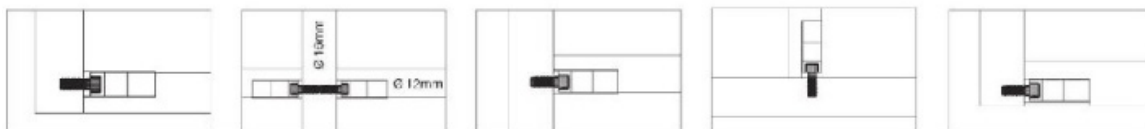

Technické informace:

Pevnost spojky bez použití kolíků (N)

Pevnost v tahu (N)

	12 Cabineo	8 Cabineo	excentr	Materiál 12 mm	Cabineo 8
Dřevotřískka 19 mm				HPL	
Pevnost v tahu (F1)	900	500	500	Multiplex	900
Pevnost ve stříhu (F2)	850	550	550	CDF	600
Pevnost ve stříhu (F3)	400 [-13%]	400 [-13%]	450	MDF	400
Přítlačná síla (F4)	900	500	-		
10 N ~ 1 kg				10 N ~ 1 kg	

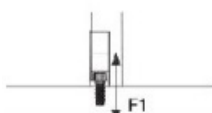

Pevnost v tahu

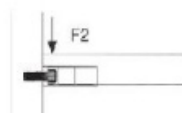

Pevnost ve stříhu

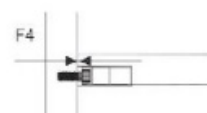
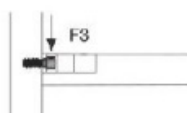

Přítlačná síla

Technické údaje

Rozměry	33.8 x 16.5 x 10.8 mm
Fréza	ø 12 mm nebo menší
Vrták	ø 5 mm a 15 mm
Z materiálu	umělá hmota se skelným vláknem
Tolerance instalace	podélně ± 1 mm